

---

# **Adapting the Off-Highway Truck Body Volumetric Process to Real World Conditions**

**LeRoy G. Hagenbuch**  
Philippi-Hagenbuch, Inc.

The appearance of this ISSN code at the bottom of this page indicates SAE's consent that copies of the paper may be made for personal or internal use of specific clients. This consent is given on the condition, however, that the copier pay a \$7.00 per article copy fee through the Copyright Clearance Center, Inc. Operations Center, 222 Rosewood Drive, Danvers, MA 01923 for copying beyond that permitted by Sections 107 or 108 of the U.S. Copyright Law. This consent does not extend to other kinds of copying such as copying for general distribution, for advertising or promotional purposes, for creating new collective works, or for resale.

SAE routinely stocks printed papers for a period of three years following date of publication. Direct your orders to SAE Customer Sales and Satisfaction Department.

Quantity reprint rates can be obtained from the Customer Sales and Satisfaction Department.

To request permission to reprint a technical paper or permission to use copyrighted SAE publications in other works, contact the SAE Publications Group.



**GLOBAL MOBILITY DATABASE**

*All SAE papers, standards, and selected books are abstracted and indexed in the Global Mobility Database*

No part of this publication may be reproduced in any form, in an electronic retrieval system or otherwise, without the prior written permission of the publisher.

**ISSN 0148-7191**

**Copyright © 2000 Society of Automotive Engineers, Inc.**

Positions and opinions advanced in this paper are those of the author(s) and not necessarily those of SAE. The author is solely responsible for the content of the paper. A process is available by which discussions will be printed with the paper if it is published in SAE Transactions. For permission to publish this paper in full or in part, contact the SAE Publications Group.

Persons wishing to submit papers to be considered for presentation or publication through SAE should send the manuscript or a 300 word abstract of a proposed manuscript to: Secretary, Engineering Meetings Board, SAE.

**Printed in USA**

# Adapting the Off-Highway Truck Body Volumetric Process to Real World Conditions

LeRoy G. Hagenbuch, P.E.  
Philippi-Hagenbuch, Inc.

Copyright © 2000 Society of Automotive Engineers, Inc.

## ABSTRACT

SAE Standard J-1363 Jan 85 reaffirmed Nov 95 has served the off-highway truck industry well. However as off-highway trucks have become larger, now approaching 400-ton capacity versus 170-ton or maybe 190-ton in the mid-1980s, and as mining operations have become more sophisticated, pennies are counting where dollars used to. And with parametric 3-D CAD design becoming the norm, the need and the possibility of more accurately defining the reality of what an off-highway truck body will carry and where that load will rest fore-to-aft on the truck chassis has become paramount. With a single tire on a 300 ton plus capacity off-highway truck costing in excess of \$25,000 to \$30,000, proper load placement and accurate truck loading are absolutely essential. The Load Profiled™ off-highway truck body design approach incorporates specific field operating parameters, i.e. material characteristics, density and angles of repose to provide an off-highway truck body that is site-specific /sized to the actual operation where the off-highway truck will be used.

## INTRODUCTION

This presentation talks about a method of profiling off-highway truck body loads in a predictive manner so as to define actual volume and load center of mass that an off-highway truck body will carry. This process results in a Load Profiled™ offhighway truck body with the right volumetric capacity, properly sized for the targeted load, matched to the loading equipment, and when used with an off-highway truck, interacts positively with the truck chassis as opposed to a body rated per SAE Standard J-1363 that ignores actual material angles of repose, body corner voids, and the loading characteristics of the loading tool. This paper describes a design process and the iterations one goes through to create a Profiled Load™ offhighway truck body that matches actual load with a truck's rated G.V.W. with proper axle loaded weight distribution of typically 1/3 front axle, 2/3 rear axle and proper body sizing. Thus, a Load Profiled™

off-highway truck body is created that interacts more favorably with the truck chassis in both the vertical load center of gravity and the horizontal load center of gravity.

## MAIN SECTION

SAE Standard J-1363 defines how a truck body's volumetric capacity is to be rated and for purposes of this presentation particularly off-highway truck bodies. Today this SAE standard though is only a starting point for determining actual volumetric rating of off-highway truck bodies. SAE Standard J-1363 Nov 95 results from a Report of the Off-Road Machinery Technical Committee approved January 1985. Reaffirmed by the SAE Machine Type Technical Committee SCI – Loaders, Crawlers, Scrapers, and Mounted Attachments, November 1995.”[1]

However, since 1985 sophistication of equipment design with 3D modeling etc. has advanced tremendously. In fact through the use of 3D modeling the sophistication in off-highway truck and truck body design has evolved several times. And as trucks have grown in size, the need for more sophistication as to off-highway truck body design and truck body performance has become ever more evident.

Just 35 years ago, a 65-ton capacity off-highway truck was considered a giant of a truck. For some off-highway truck manufacturers in the mid-1980s, an 85-ton capacity truck was the standard. Today these same manufacturers are producing trucks 300-ton plus in size and in fact today as truck size has grown the need for more advanced body design analysis efforts has grown in sophistication and complexity, SAE Standard J-1363 thus appears to be in need of some rethinking.

To understand that statement, let's review how this standard rates the volumetric capacity of an off-highway truck body. This standard states to measure the truck capacity of an off-highway truck body you close off the open rear-end of an off-highway truck body starting at

the rear edge of the floor plate with a theoretical line drawn upward at a 1:1 slope to the water line or top of body sides. SAE Standard 3.22 For bodies with one end or side open, the volume shall be limited by a plane passing through the outer edge of the opening and top corners of the adjacent side plates or at a slope of 1:1 extending inward and upward from the outer edge of the opening, whichever gives the smaller capacity.”[1] This in itself is fine from the theoretical standpoint; however only at the extreme end of the material angle of repose spectrum and in only very limited cases will any material heap at a 1:1 slope; and this struck body volume standard, as it exists today, is used in rating both the struck and heaped body volumetric capacity.

To rate the entire off-highway truck body capacity then add struck capacity plus any load heap (almost any material hauled will support in some way, shape or form some type of load heap above the body sides). This is where SAE Standard J-1363 really begins to self-destruct as J-1363 specifies for load heap above the body sides (the heaped capacity) of an off-highway truck body to be figured at a 2:1 slope or 2:1 heap from all points around the truck body: body sides, front slope, body rear (that theoretical point/line where the 1:1 theoretical rear load slope line intersects the top of the body sides). SAE Standard 3.3.1 Heaped capacity of a dumper or trailer body shall be the sum of the struck volume and the top volume enclosed by the four planes at a slope of two horizontal to one vertical (2:1) extending inward and upward from the mean lines of the sides and end plates or load-carrying extensions thereof. For bodies with open ends or sides, the 2:1 slope for heaped capacity shall start from the top of the 1:1 slope which determines struck volume.” [1] This struck volumetric rating per J-1363 of a 1:1 slope in and of itself is at the least questionable if not downright wrong (few materials will hold a 1:1 slope even momentarily – some sticky, very cohesive clay materials might). But to put a 2:1 material heap on top of the 1:1 struck heap is wrong. What kind of material heaps are realistic?

To say that material in an off-highway truck body will heap at a 1:1 slope from the rear edge of the floor plate to the body sides or water line and then when further material is heaped/loaded onto the body that this same material will then heap at a 2:1 slope is a bit hypocritical as it means, in fact, that material at the rear of the body placed above the body sides will only heap at a 2:1 slope while material below the body sides (this same material) will heap at a 1:1 slope.

Frankly it is a bit foolish for SAE Standard J-1363 to define a 2:1 SAE”heaped load that requires material at a 1:1 load heap (at the body rear below the body sides) to support material above the body sides that supposedly will only heap at a 2:1 load heap. Yes, it is inconsistent to have part of the 2:1 load heap definition actually be a 1:1 load heap.

This is why every off-highway truck manufacturer includes three (3) letters after every otherwise unannotated 2:1 load heap rating, those three (3) letters ‘SAE’. Really if the material in the load is all the same whatever slope the material heaps to above the body sides is the slope that will exist below the body sides. In its current form, this SAE standard overrates the effective body volumetric capacity, and when bodies are deeper at the rear, overrating is greater than with bodies that are shallower at the rear (Figure 1).

Referring to an off-highway truck manufacturer’s handbook: [2]

MATERIAL	ANGLE BETWEEN HORIZONTAL AND SLOPE OF HEAPED PILE	
	Ratio	Degrees
Coal, industrial ... ..	1.4:1 – 1.3:1	35-38
Common earth, Dry... ..	2.8:1 – 1.0:1	20-45
Moist... ..	2.1:1 – 1.0:1	25-45
Wet... ..	2.1:1 – 1.7:1	25-30
Gravel, Round to angular... .	1.7:1 – 0.9:1	30-50
Sand & clay... ..	2.8:1 – 1.4:1	20-35
Sand, Dry... ..	2.8:1 – 1.7:1	20-30
Moist... ..	1.8:1 – 1.0:1	30-45
Wet... ..	2.8:1 – 1.0:1	20-45

Table 1

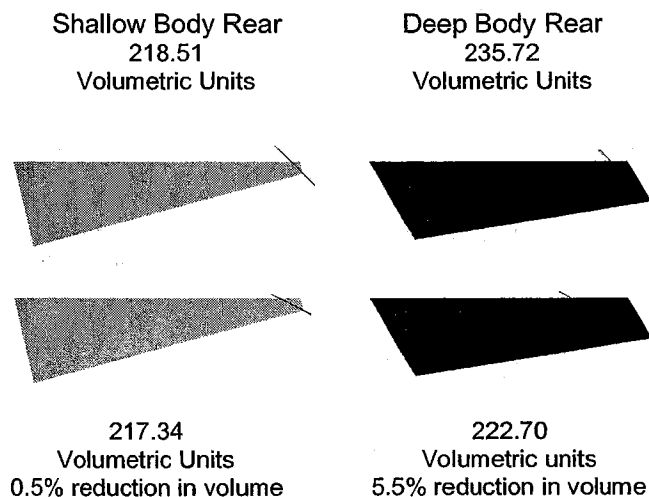

Figure 1.  
The Difference in Body Volumetric Ratings When Going From a Rear 1:1 Slope to a 2:1 Slope

Off-highway truck manufacturers, as an industry, have in some cases attempted to address this anomaly as to actual effective body volumetric capacity versus theoretical body capacity. Off-highway truck manufacturers have done it in a number of ways. One manufacturer developed what they call the ‘Field Heap’ which assumed a true 2:1 material heap from all points

around the body: the rear edge of the floor, body sides, and body front wall (Figure 2).

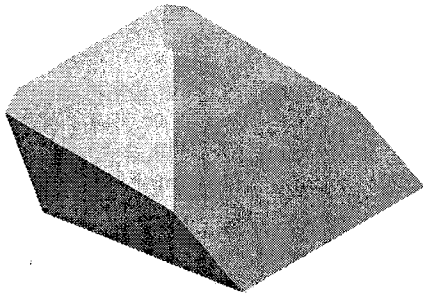

Figure 2  
2:1 Slope Field Heap  
9.5% Less Volume than the  
2:1 SAE Heap

Another truck manufacturer added this note to their off-highway truck spec sheets: "SAE Heap generally adds 5-6% to capacity, but is not achievable in practice." [3] So, yes it has been recognized by others that the SAE 2:1 heaped volumetric rating has some significant fallacies.

A field heap capacity and/or notes like this are hardly reassuring as to the SAE 2:1 Heap Standard's viability. However, whatever the off-highway truck body heaped rating 1:1, 2:1, SAE 2:1 or Field Heap", all, I repeat, ALL of these methods rely on another totally impractical reality. All of these standard approaches for rating an off-highway truck body's volume, even today, rely on another truck body volume rating fallacy. This impracticality, that all of these approaches still rely is to have flat intersecting material load planes defining off-highway truck body volumetric capacity. This is not only impractical but also impossible (Figure 3).

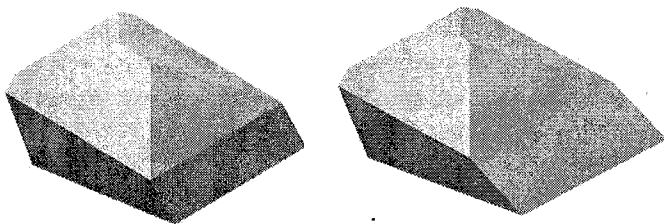

Figure 3  
Body Volumetric Rating With Flat  
Intersecting Load Planes

By flat intersecting load planes, we mean for instance a flat load plane with one edge defined as the entire length of the body side and a second edge defined where the heap of the load meets at the middle of the truck (a totally flat plane). Similarly for the front and rear of the body – a flat plane starting at the front edge

or across the rear edge of the body. Material simply doesn't conform to such flat planes when loaded into a truck body. (Photo 1)



Photo 1

Stepping back for a moment, is this whole issue much to do about nothing? No, it's not! Why the concern about how to rate off-highway truck body volumetric capacity, (open-rear-ended) truck bodies? There are at least two main reasons for this concern!

First, the user/owner. An off-highway truck purchaser / user needs – must have an accurate and true truck body rating to properly specify and purchase the right / correct equipment. If one is opening up a mine and wants to move a specific volume of material daily, weekly or annually then one must know two things: the density of the material to be moved and the volumetric capacity required in an off-highway truck body to move that material. Off-highway truck haulage effectiveness/efficiency is determined by these two factors:

- a. Density of the material being hauled
- b. Effective truck body volume (to achieve optimum payload)

Multiplying these two factors together gets actual payload an off-highway truck moves. Whether that payload fully utilizes the truck or not is totally contingent on "effective" truck body volume. In today's world one cannot operate on the theoretical if the theoretical does not approximate the actual! A theoretical payload based upon a theoretical body volumetric rating standard leaves an off-highway truck purchaser out in the cold!

Second, the off-highway truck designer. An off-highway truck designer must be able to accurately define both what an off-highway truck body will carry and how that load will sit fore-aft and side-to-side on the off-highway truck chassis. These questions are extremely important to overall off-highway truck operating life. From an off-highway truck designer's standpoint, only if one can accurately define a body's anticipated volumetric load profile, will it be possible to actually define the load's center of gravity. As can readily be understood, until one can precisely define an off-highway truck body's

anticipated volumetric load profile will it be even remotely possible to define the load's center of gravity for proper body placement on an off-highway truck chassis. Only with the load center defined is it possible to position an off-highway truck body for a proper 1/3 – 2/3 loaded vehicle axle weight distribution. With just off-highway truck tires on large 240-300 ton class off-highway trucks costing in excess of \$25,000 per tire, it is very important that the off-highway truck body and corresponding load be placed correctly on an off-highway truck chassis to fully utilize front axle/rear axle loadings for proper loaded axle weight distribution between front axle and rear axle. And, when one further considers the effects on chassis structural integrity, hydraulic hoist system, operator safety, and vehicle stability, the stakes in proper load to chassis placement are astronomical.

Current off-highway truck body volumetric rating methods define loads that are not only impractical but also impossible to carry. Reflecting on this statement, take any material and dump it on a flat surface and what do you get? Any material dumped any place is going to form a natural cone. (Figure 4)

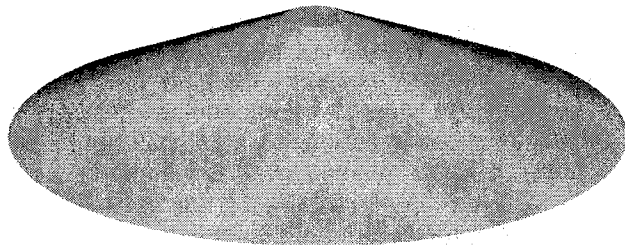

Figure 4

And material dumped in the corner of three intersecting planes (a bottom and two intersecting side planes) will still take on the shape of a cone all be it a truncated cone with some exception to a consistent material angle of repose (more on that later). (Figure 5)

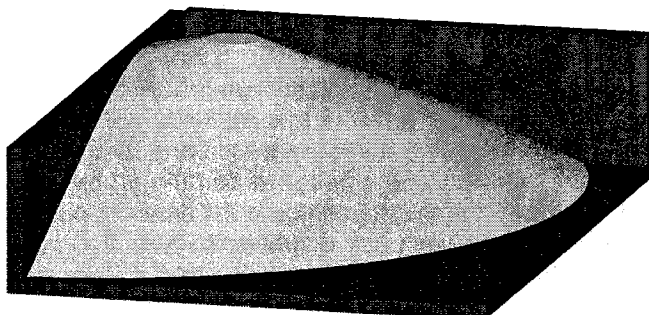

Figure 5

Why does material always form a cone or truncated cone when dumped from any device: shovel, front-end loader, or hopper? In two phrases: static friction and angle of repose. What is static friction? What is angle of repose? A direct quote from an Engineering book: "Static friction is the force, in addition to that overcoming inertia, required to set in motion one body in contact with another"[4] and "The angle of repose is the angle of inclination of the surface of one body at which the other body will begin to slide along it under the action of its own weight. The angle of repose ( $\mathbf{A}$ ) is equal to the angle of static friction."[4] While the "Angle of static friction ( $\mathbf{A}$ ) for two surfaces with a normal pressure  $\mathbf{N}$  and a static friction  $\mathbf{F}$  between them. [ $\mathbf{N}$  and  $\mathbf{F}$  in the same units]

$$\tan \mathbf{A} = \frac{\mathbf{F}}{\mathbf{N}} = f \quad [4]$$

Translation: all materials (particularly material hauled by off-highway trucks) have a "angle of repose" and this angle will/does define how material sits in an off-highway truck body.

Some typical angles of repose are [4]:

Materials	Condition	Sliding Friction		Static Friction	
		$\mathbf{A}$	$\mathbf{F}$	$\mathbf{A}$	$\mathbf{F}$
Earth on earth	—	—	—	14°-45°	0.25-1.0
Earth on earth (clay)	Damp	—	—	45°	1.0
Earth on earth (clay)	Wet	—	—	17½°	0.31
Steel on ice	Dry	—	0.014	—	0.027
Stone masonry on undisturbed ground	Dry	—	—	33°	0.65
Stone masonry on undisturbed ground	Wet	—	—	16½°	0.30

Table 2: Typical Angles of Repose

And, again from a truck manufacturers handbook as previously mentioned [2]

the back of the truck body and from side to side of the truck body (Photo 2)

Angle of Repose of Various Materials		
MATERIAL	ANGLE BETWEEN HORIZONTAL AND SLOPE OF HEAPED PILE	
	Ratio	Degrees
Coal, industrial ... ..	1.4:1 – 1.3:1	35-38
Common earth, Dry... ..	2.8:1 – 1.0:1	20-45
Moist... ..	2.1:1 – 1.0:1	25-45
Wet... ..	2.1:1 – 1.7:1	25-30
Gravel, Round to angular... ..	1.7:1 – 0.9:1	30-50
Sand & clay... ..	2.8:1 – 1.4:1	20-35
Sand, Dry... ..	2.8:1 – 1.7:1	20-30
Moist... ..	1.8:1 – 1.0:1	30-45
Wet... ..	2.8:1 – 1.0:1	20-45

Table 3

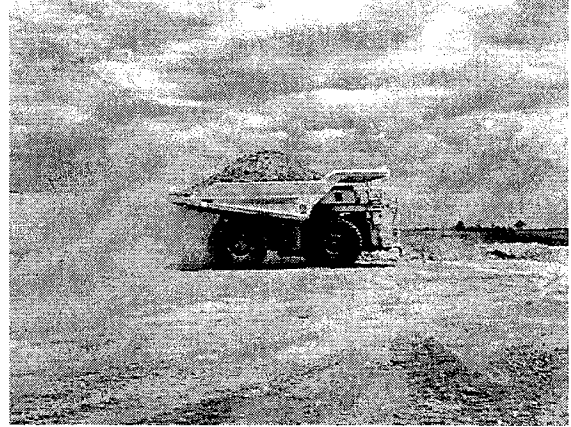

Photo 2. Sample Photograph Taken at a Mine Site

Before we go too far with this angle of repose question, it does follow that all materials do have an angle of repose (even water has an angle of repose though it is 0 degrees). It would seem then very practical to simply rate an off-highway truck body's volumetric capacity using a truncated cone approach and a material's fixed angle of repose (Figures 6 and 7).

In fact, field experience gained measuring material angles of repose hauled in off-highway truck bodies has universally supported the fact that the angle of repose of material loaded in off-highway truck bodies varies front to back and side to side, in open-ended off-highway truck bodies (Photo 3).

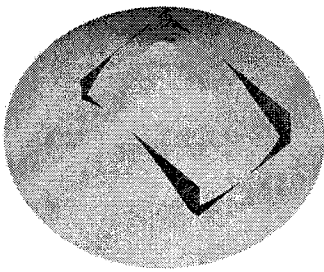

Figure 6

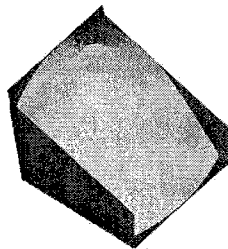

Figure 7

However the effective volumetric rating of off-highway bodies is not quite that simple. It seems very logical to simply measure a material's angle of repose and create a conical volumetric load profile to theoretically rate an off-highway truck body's volumetric capacity. After all couldn't one visit a site where purposed off-highway trucks might operate (assuming a currently operating mine, construction site, etc.), photograph several off-highway trucks being loaded on the haul road and at the dump site, then blow up selected photographs and physically measure the hauled material's angle of repose.



Photo 3. Demonstration of Load Carried in a Body

No, unfortunately it is not that simple. When various field angles of repose were measured, a somewhat surprising fact emerged. It was found that the angle of repose of material being carried in off-highway truck bodies, even on a single load of material varies on that same load of material from the front of the truck body to

However, field experience has also universally supported the fact that the various angles of material repose in a loaded off-highway truck body are always steeper to the rear and shallower to the front while the side to side angle of material repose is generally the same, left to right and right to left (table 4).

Measured Material Angles of Repose				
Material	Mine	<u>Front Angle</u>	<u>Rear Angle</u>	<u>Side Angle</u>
Overburden	Coal	24°	28°	34°
Overburden	Coal	21°	31°	33°
Overburden	Coal	24°	31°	24°
Waste/Ore	Copper	29°	31°	24°

Table 4: Material Angles of Repose

So how do we explain this flatter angle of material repose to the front of an off-highway truck body and steeper angle of material repose to the rear of the truck body? (Figure 8)

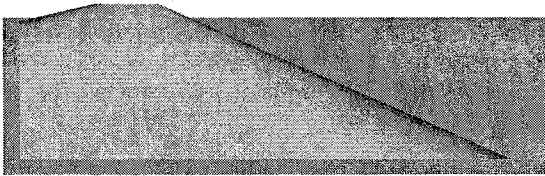

Figure 8

As stated before all materials, even water, have an angle of repose, and just as similarly all materials as moved and allowed to flow from one vessel to another exhibit fluid/flow-dynamic characteristics. Thus as material is dumped into an off-highway truck body that material operates in a fluid dynamic state. (Figure 9).

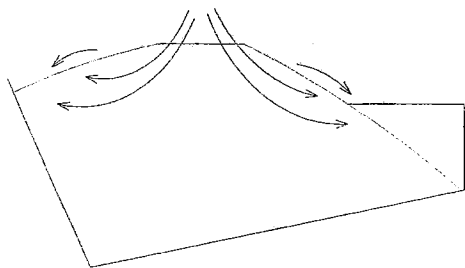

Figure 9

To help explain the flatter angle of repose to the front of an off-highway truck body, consider what happens when you place your foot across the middle of a 600 mm wide shallow 75 mm deep fast flowing stream of water. The water boils up to the front of the upstream side of your foot. Similarly as material flows in a fluid dynamic state against an off-highway truck body's front plate/front wall, it boils up some and comes to rest at a flatter angle than the true material angle of repose.

A similar though not as marked result, depending on an off-highway truck body's width compared to length, occurs side to side in an off-highway truck body. The material angle of repose in an off-highway truck body's front and sides is contrary to what occurs at the body rear where nothing impedes the material flow out the rear of the body. This rear angle of material repose is totally unrestricted and thus is more like the material's "natural" angle of repose. The material fluid dynamics flow to the body rear being unrestricted will generally always have a steeper angle of repose than flow to a restricted body front or side unless the off-highway truck body is unusually narrow.

Great, so now it is understood one does not have a constant angle of repose around all four sides of the same off-highway truck body load. The question then becomes how do we make use of these various angles of repose, front to rear and side to side, and accurately reflect the volumetric load profile of an off-highway truck body's load?

A method has been developed that allows the merging of these various angles of repose around a truck body to accurately depict the resultant volumetric load profile being carried in an off-highway truck body (Figure 10).

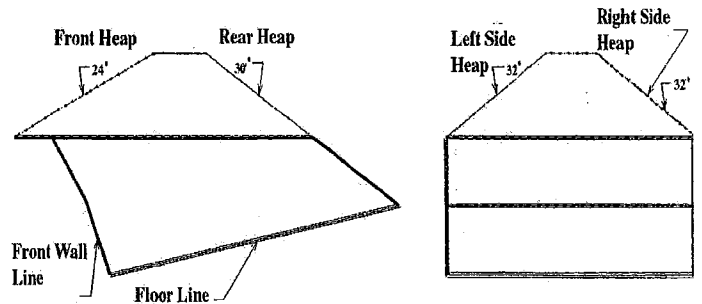

Figure 10

This method uses a differential process to blend or merge the angles of repose from the front of an off-highway truck body to the side of the body and from the body sides to the rear. This differential process as depicted in Figure 11 allows for a very accurate depiction of what actually occurs in the field use of off-highway truck bodies. This depiction creates a very accurate load profile (Figure 12) for determining the true volumetric load carrying capabilities of an off-highway truck body (Figure 13) which correspondingly allows one to just as importantly accurately define the load center of gravity of this load profile which allows proper body placement on the off-highway truck chassis (Figure 14) and with proper body placement a correct loaded off-highway truck loaded axle weight distribution can be obtained, typically 1/3: 2/3 axle distribution on off-highway trucks.

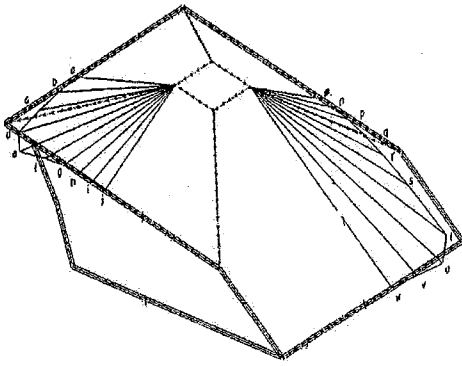

Figure 11

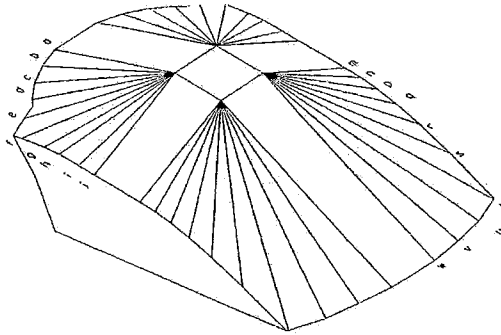

Figure 12 Finished Heap

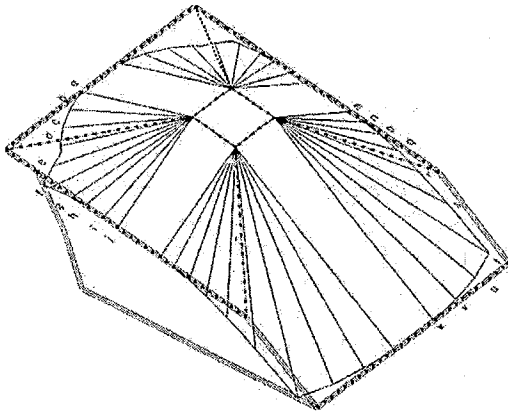

Figure 13 Finished Heap

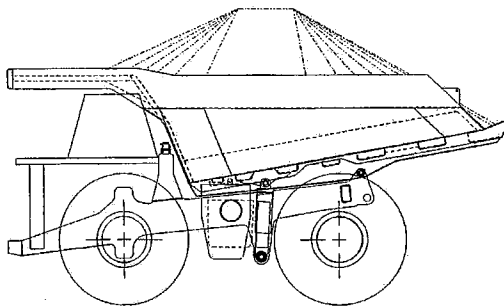

Figure 14

The whole "load profile" body design process begins by defining a floor line and a front slope line of the off-highway truck body (Figure 15) and then defining body width or body side positioning (Figure 16).

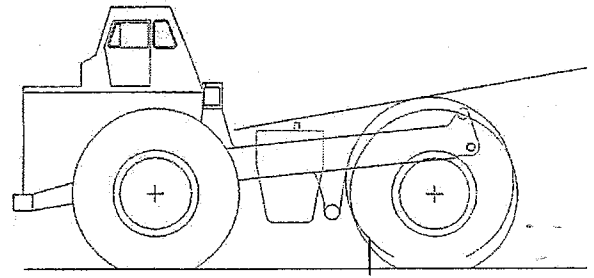

Figure 15

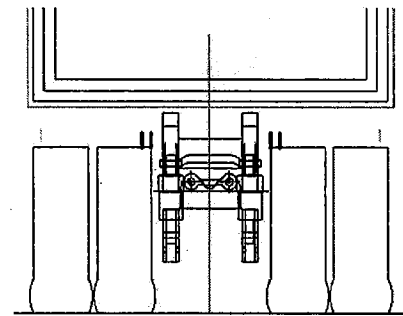

Figure 16 Establish Proposed Body Width

At that point a theoretical load volumetric profile blending the three (3) different angles of repose (body front, sides, and rear) is drawn into the truck body. A center of gravity of load is determined and at that point the body sides are raised or lowered, the front of the body is moved forward or backward, and the body floor is flattened or tipped up steeper to arrive at both the required body volume and correct load center of gravity. Then working through an iterative process with these four body defining components (front, side, and floor), the load volumetric capacity and load center of gravity are calculated. With the correct load volumetric "load profile" and load center of gravity defined, the body is then positioned exactly as needed between the front and rear axles.

Let's compare three identical sized bodies and the different volumetric ratings we get: (1) Load Profiled™ bodies with three different angles of repose: front, side and rear (Figure 17) (2) bodies designed with a straight 2:1 heap or 2:1 field heap (Figure 18) and (3) bodies designed according to the SAE 2:1 Heaped Standard (Figure 19).

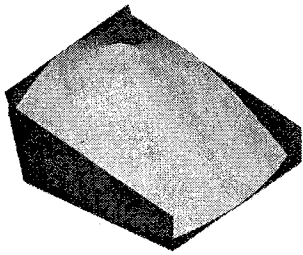

Figure 17  
Load Profiled™ Bodies  
155.3 Volumetric Units

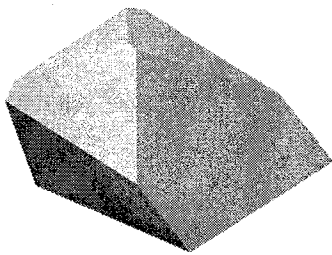

Figure 18  
Bodies with a Straight  
2:1 Heap or 2:1 Field Heap  
165.9 Volumetric Units

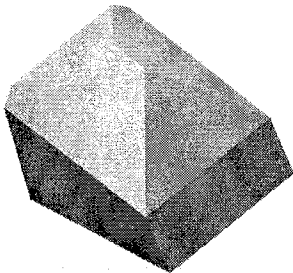

Figure 19  
Bodies Designed According to SAE  
2:1 Heap Standard  
183.4 Volumetric Units

However at this point a word of caution is in order. As angles of repose change, the variances between the three different body rating/sizing methods either grow or lessen, i.e. in some cases the SAE 2:1 heaped rating could be very correct while in other cases it is way off. However even with that having been said, the only way to accurately determine correct load center of gravity is by accurately depicting through the load profiled™ process a true volumetric load profile that the off-highway truck designer can anticipate the body will be carrying. So even if by some chance the body volumes turn up similar numbers invariably the load center will be way off between the three body volumetric rating methods with only one being right (Figure 20).

Starting with exactly the same body, begin by loading it using three different material profiles.

1. Load Profiled™
2. 2:1 Heap from all points
3. SAE 2:1 Heap

Now how do these three (3) load profiles impact load center of gravity? The vertical line through all these profiles depicts where the load center of gravity should fall. The top load profiled™ is an accurate depiction of how the load truly will sit in the body and where the load center will really be.

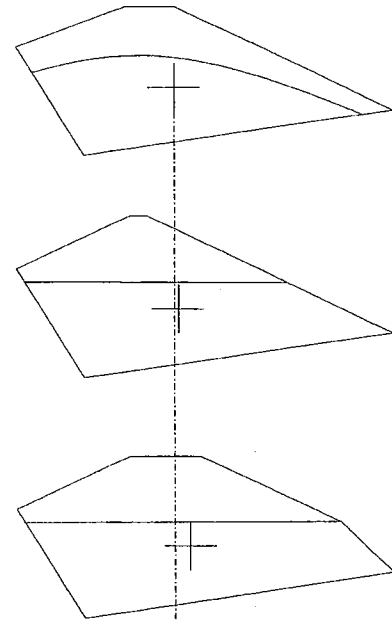

Figure 20

Moving to the middle diagram, a 2:1 heaped load profile: the cross hairs of this diagram depict the true load center of gravity which in this case means that the load would be 1.5% of the off-highway truck's wheel base too far rearward. Thus a truck designer would move the body forward on the truck chassis which automatically, when a (actual) field load is placed in the body, overloads the truck's front axle. Maybe this is why 95% plus of the time a truck's front tires wear out first.

Finally the bottom diagram, the SAE 2:1 heaped load profile, again the cross hairs depict the actual load center of gravity which is way too far to the rear of the targeted load center placement. The cross hairs are in fact 6.0% of the off-highway truck's wheel base too far to the rearward from the targeted load placement. So for the novice designer if somehow they felt the SAE 2:1 heaped load was correct they would move the truck body forward to the target point and then really be overloaded to the off-highway truck's front axle.

Frankly, this is where the rubber meets the road. For example, if the load placement on the chassis of a 240-ton off-highway truck is not correct that truck could end up with either the front axle or rear axle being at maximum permissible load while the overall load on the vehicle might only be 200 tons. In fact as vehicle or chassis variations occur (different engines, extended front bumpers, etc.), load placement becomes even more variable to get maximum allowed gross vehicle weight while having the correct axle weight distribution.

So from both a truck purchaser's / user's standpoint and the truck designer's standpoint, they need to know a true off-highway truck body rated volumetric capacity and true center of gravity of load to achieve the right axle weight distribution with maximum effective payload.

## CONCLUSION

Only when true off-highway truck body rated volumetric capacity and true center of gravity of load are known, are off-highway truck designers and purchasers able to take a significant variable out of the equation which allows for both correct axle weight distribution with maximum effective payload. The other variable, material density, is one that, though not easily defined, can be fairly accurately defined with today's techniques. [5] With these three points, true effective body volumetric rating, companion load center of gravity and actual material density, a truck user today can get maximum productivity and utilization out of their off-highway truck fleets.

## ACKNOWLEDGMENTS

The author wishes to acknowledge the following persons with Philippi-Hagenbuch, Inc. for their assistance with preparing this paper: Phil Brinkman, Product Designer; Lauri England, Marketing Manager; and Susan Hudson, Assistant to the President.

## REFERENCES.

1. SAE Standard Capacity Rating-Dumper Body and Trailer Body-SAE J1363 NOV95
2. An off-highway truck manufacturer's handbook. Please contact author for more specifics.
3. An off-highway truck manufacturer's spec sheets. Please contact author for more specifics.
4. Hudson, Ralph G. The Engineers Manual. John S. Wiley and Sons, Inc. New York: 1939.
5. "Automated Volume Measurement of Haul-Truck Loads." A paper by Elliott Duff of CSIRO Manufacturing Science and Technology. Presented at Open Coal Cut Operations Conference June 16, 2000 in Mackay, Queensland.

## CONTACT

LeRoy Hagenbuch is a 1966 University of Illinois Agricultural Engineering graduate. He is a registered Professional Engineer who, with L.B. Philippi, formed Philippi-Hagenbuch, Inc. in 1969.

Mr. Hagenbuch, who currently serves as Chairman of this solutions-oriented design engineering and sales company, holds numerous patents related to material haulage equipment and directs his company's efforts relative to research and development, product design, and key customer account development.

For further information about this paper, LeRoy can be contacted at [lhagenbuch@philsystems.com](mailto:lhagenbuch@philsystems.com). Also please visit Philippi-Hagenbuch, Inc's web site at [www.philsystems.com](http://www.philsystems.com).